

RECIPROCATING

**A-SERIES**

reliability, durability, quality



COMPRESSORS

# A-SERIES

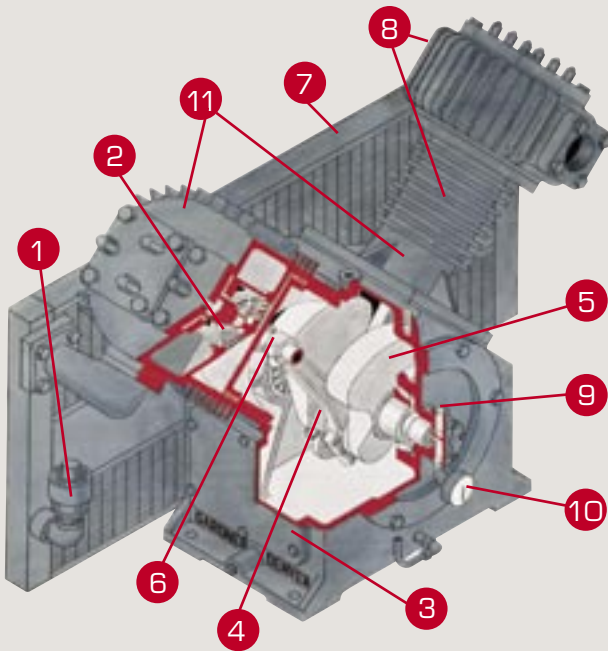

## PERFORMANCE FEATURES

1. ASME pressure relief valve protects the intercooler and first stage from over pressure.
2. Suction unloading valves provide loadless starting and stopping as well as quick response to capacity demands.
3. Removable hand-hole plate allows easy access to the internal running gear.
4. Tri-Metal insert bearings are two-piece for quick and easy replacement.
5. Counterbalanced crankshaft assures smooth operation.
6. Replaceable piston pin bearings are very economical when replacement becomes necessary.
7. Generously sized intercooler provides maximum cooling for the most efficient operation and low power consumption. (AVLAVCAA-GD only)
8. Deep-finned cylinders and heads quickly dissipate the heat of compression.
9. Crankshaft ends are supported by large tapered roller bearings for smooth operation and long life.
10. Oil pressure gauge assures the operator of lubrication system integrity.
11. The cylinders and crankcases are built of industrial strength cast iron materials.

## MAJOR APPLICATIONS

- Bulk Material Handling
- Engine Starting
- Mines Air
- Well Head Servicing
- Petroleum Refineries
- Plant Air and Vacuum

The Gardner Denver ATLE6 is a single stage, two cylinder, pressure lubricated compressor that is equipped with an SAE#3 bell housing flange for direct engine mounting and remote site operation.

Wherever there's a demand for a low pressure engine driven compressor, the ATLE6 is the compressor for the job. Because it is direct coupled to the engine, there is no need to worry about belts slipping or wearing out. When connected to the engine, all rotating components are totally enclosed and protected from the environment.

The Gardner Denver APL and APO are single stage, two cylinder, pressure lubricated compressors equipped with a two-groove, 17 inch sheave for belt driven applications. The APL and APO have an integrated cooling fan built into the cast iron sheave for maximum cooling.

The AVLEK is a single stage vacuum pump, AVLAN is a single stage booster and the AVLAV is a two-stage compressor. All A-Series compressors are designed to provide optimum performance in a wide variety of operations.

## LUBRICATION

- Superior lubrication is accomplished through a gear driven oil pump powered by the crankshaft.
- Pressurized system ensures complete lubrication to the crankshaft, connecting rods, bearings and piston pins.
- Full flow, spin-on oil filter ensures impurities are removed before the lubricant contacts any internal components.
- Oil pressure gauge is conveniently mounted to display the oil pump pressure.

## VALVES

- Concentric ring design incorporates both the inlet and outlet valves in one assembly.
- Designed to give 100% exposure to the air flow for maximum efficiency (i.e. more CFM per HP).
- Made of AISI 420 stainless steel to give dependable corrosion-free and fatigue-free service life.



**APLGAA-GD, APLGBA-GD, APLHAA-GD & APLHBA-GD  
APOGAA-GD, APOGBA-GD, APOHAA-GD & APOHBA-GD**

28" HG-60 PSIG (0.95-4.1 BARg), Continuous Operation  
7.5-30 HP (5.6-22 kW), 5-15 HP (3.75-11.2 kW)

**DIMENSIONS**

Model	Bore Diameter		Stroke	Inlet	Discharge	Dimensions L x W x H	Weight	
	in	mm					lbs	kg
APL	in	7.875	3	3	3	41 x 29 x 30	lbs	750
	mm	200	76	76	76	1041 x 737 x 762	kg	340
APO	in	7.875	4.5	3	3	41 x 29 x 30	lbs	750
	mm	200	114	76	76	1041 x 737 x 762	kg	340

**COMPRESSOR SPECIFICATIONS**

Model	Speed hp/kw	Pressure		Capacity	
		psig	barg	cfm	m <sup>3</sup> /min
APL	855 15/11.2	20	1.4	113	3.2
		30	2.1	105	3.0
		40	2.8	98	2.8
		50	3.4	90	2.5
		60	4.1	83	3.1
APO	698 20/15	20	1.4	145	4.1
		30	2.1	134	3.8
		40	2.8	125	3.5
		50	3.4	117	3.3
APO	885 25/19	20	1.4	181	5.1
		30	2.1	169	4.8
		40	2.8	158	4.5
		50	3.4	148	4.2
		60	4.1	138	3.9
APO	1072 30/22	20	1.4	218	6.1
		30	2.1	205	5.8
		40	2.8	192	5.4
		50	3.4	180	5.1
		60	4.1	168	4.8

**VACUUM PUMP SPECIFICATIONS**

Model	Speed hp/kw	Capacity		Vac. - HG	
		cfm	m <sup>3</sup> /min	in	mm
APL	780 5/3	120	3.4	5	127
		114	3.2	10	254
		105	3.0	15	381
		92	2.6	20	508
		60	1.7	25	635
APO	739 7.5/5.6	167	4.7	5	127
		164	4.6	10	254
		157	4.4	15	381
		145	4.1	20	508
		99	2.8	25	635
APO	937 10/7.5	198	5.6	5	127
		193	5.5	10	254
		185	5.2	15	381
		169	4.8	20	508
		117	3.5	25	635

**ATLE6-GD**

**DIMENSIONS**

Model	Bore diameter		Stroke	Suction & Discharge Pipe Size NPT	Dimensions L x W x H	Weight	
	in	mm				lbs	kg
ATLE6-GD	in	7.875	3	3	41 x 29 x 30	lbs	750
	mm	200	76	76	1041 x 737 x 762	kg	340

**SPECIFICATIONS**

Speed rpm	Piston Displacement		Oil Capacity		Maximum Pressure		Discharge Air Temp		Duty Cycle	Flow		BHP	
	cfm	m <sup>3</sup> /min	quarts	liters	psig	barg	°F	°C		cfm	m <sup>3</sup> /min	hp	kw
	@ 30 psig — 2.07 bars												
1550	262	7.8	9	8.5	30	2.07	400	204	intermittent	180	5.1	29	22



**APL**  
Single Stage Compressor

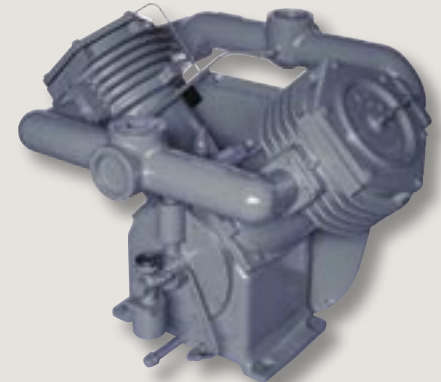

**APO**  
Single Stage Compressor



**ATLE6-GD**  
Single Stage Compressor



**ATLE6-GD**  
Typical ATLE6-GD compressor direct connected to an internal combustion engine.  
*Note: Engine and coupling supplied by others.*

## AVLAVCAA-GD, AVLANCAA-GD, AVLEKCAA-GD

25" HG VAC – 350 PSIG (0.8 BAR VAC – 24.1 BARg)  
 Continuous Operation 7.5-40 HP (5.6-30 kW)

### DIMENSIONS

Model	Bore Diameter	Stroke	Inlet	Discharge	Dimensions L x W x H	Weight
AVLAVCAA-GD	in 8.00/4.25	4.50	3.0	2.0	40 x 27 x 33	lbs 680
	mm 203/108	114	76	51	1016 x 686 x 838	kg 308
AVLANCAA-GD	in 4.25	4.50	2.0	2.0	38 x 27 x 33	lbs 600
	mm 108	114	51	51	965 x 686 x 838	kg 272
AVLEKCAA-GD	in 7.50	4.50	3.0	3.0	38 x 27 x 33	lbs 600
	mm 191	114	76	76	965 x 686 x 838	kg 272



**AVLEKCAA-GD**  
Single Stage Vacuum Pump

### COMPRESSORS SPECIFICATIONS

HP --- kW	Speed	Pressure		Capacity	
		psig	bars	cfm	m <sup>3</sup> /min
AVLAVCAA-GD					
25 --- 19	968	100	6.90	101	2.86
	922	125	8.62	96.5	2.73
	830	175	12.07	85	2.41
	784	250	17.24	78	2.21
30 --- 22	1106	100	6.90	116	3.29
	1014	125	8.62	105	2.97
	968	175	12.07	99	2.80
	876	250	17.24	87	2.46
AVLANCAA-GD					
40 --- 30	Suction Pressures: 1-140 psig Discharge Pressure: up to 350 psig				

### VACUUM PUMP SPECIFICATIONS

HP --- kW	Speed	Capacity		Vac. - HG	
		cfm	m <sup>3</sup> /min	in	mm
AVLEKCAA-GD					
7.5-10 --- 5.6-7.5	870	169	4.79	5	127
		160	4.53	10	254
		146	4.13	15	381
		122	3.46	20	508
		62	1.75	25	635



**AVLANCAA-GD**  
Single Stage Booster

Authorized Gardner Denver Distributor



**AVLAVCAA-GD**  
Two Stage Compressor

**Gardner  
Denver**®



© 2004 Gardner Denver, Inc.  
<http://www.gardnerdenver.com>    [respond@gardnerdenver.com](mailto:respond@gardnerdenver.com)  
 1-1-5-215 1st Ed. 9/04  
 Supersedes 1-1-5-220, 1-1-5-225,  
 1-1-5-234, 1-1-5-237

Litho in U.S.A.

For additional information contact your local representative or Gardner Denver Compressor Division, 1800 Gardner Expressway, Quincy, Illinois 62301  
 Customer Service Department Telephone: (800) 682-9868 FAX: (217) 228-8243  
 Sales and Service in all major cities.  
 For parts information, contact Gardner Denver, Master Distribution Center, Memphis, TN  
 Telephone: (800) 245-4946 FAX: (901) 542-6159